

# **DIGITAL POWER CLAMP**

**Model : M9911**

**OPERATION MANUAL**





## CONTENTS

SAFETY INFORMATION	1
SAFETY SYMBOLS	1
SAFTY PRECAUTIONS	2
GENERAL DESCRIPTION	2
FEATURE	3
METER LAYOUT	4
OPERATING INSTRUCTIONS	6
AC Voltage Measurement	6
AC Current Measurement	8
Active Power Measurement	10
Power Factor Measurement	12
Apparent Power Measurement	14
Reactive power Measurement	15
Active Energy Measurement	16
Frequency Measurement	17
TURE RMS MEASUREMENT AND AVERAGE SENSING	
MEASUREMENT	19
DIAGRAM OF CURVE OF POWER	20
BACK LIGHT DISPLAY	21
INPUT VOLTAGE AND CURRENT	21
LOW VOLTAGE INDICATION	22
SPECIFICATIONS	22
ACCESSORIES	26
PRINCIPIUM CONFIGURATION	27

## SAFETY INFORMATION:

Digital power clamp has been designed according to IEC1010-1 and IEC1010-2-032 concerning safety requirements for electrical measuring instruments and handheld clamps with overvoltage category (CAT□).

### SAFETY SYMBOLS :

-  Important safety information, refer to the operating manual
-  Dangerous voltage may be present.
-  Earth ground
-  Double insulation (Protection class□)

### WARNING

Before opening the case of battery, always disconnect test leads from measurement circuits. Never use the meter unless the back cover is fastened completely. If the display shows "🔋", the battery must be replaced to ensure proper operation. To change the battery, please follow these steps:

1. Disconnect test leads from any live source, turn the rotary function switch to OFF, and remove the test leads from the input terminals.
- 2□ Using a screwdriver, remove the screw from the battery cover and remove the battery cover.
- 3□ Remove battery and replace with a new equivalent 9 Volt battery□
- 4□ Replace the battery cover and reinstall the screw.

## **SAFETY PRECAUTIONS**

- Read these operation instructions thoroughly and completely before operating your meter. Pay particular attention to WARNING. The instructions in these warnings must be followed.
- Using the meter with the equipped test leads is only conform to safety requirements. If you need instead broken test leads, you must replaced with the same as type and electric specification.
- Always inspect your meter and test leads before every use. If any abnormal conditions exist :broken test leads, cracked cases, LCD not reading, etc, do not attempt to take any measurement.
- You must be careful when working with voltages above 30V AC. Keep fingers behind the probe barriers while measuring.
- Never use the meter to measure voltages that might exceed the maximum allowable input value of any function measurement mode.
- Do not expose the instrument to direct sunlight, extreme temperature or moisture.

## **GENERAL DESCRIPTION**

Digital power clamp meter is a handheld aptitude meter with power measurement, it is incorporated current meter and power measurement instrument. The meter is composed of three channels: voltage, current, power and single chip Microcontroller. It has powerful measuring and data processing software, and complete to measure, calculate and display of the 8 parameters: voltage, current, active power, power factor, apparent power, reactive power, active energy, frequency. It has Stable capability, easy operation. It is especially suitable for measurement and overhaul of the electric power equipment and the power-supply circuit on the spot. The structure of the instrument is pincers, it is very small, very light and portable, make measurement easy and fast. To the power measurement user, the digital power clamp is one of the best instrument.

## Feature□

1. The instrument can complete the true RMS value measurement. If there is nonsinusoidal AC current input signal, it can accurately measure the active current.
2. Using autorange switch circuit and modulus transducer which has 13 bits and high resolution, the instrument has high accuracy and easy operation.
3. Adopting the power measurement system that is made of American new special chip for high accuracy power measurement and the new single chip microprocessor which has high capability and large content and is for special meter, the instrument has high integration and reliable capability. The large capability software can complete multicontrol, complex calculation and measuring display for the power measurement system.
4. Minimum current of active energy measurement is 0.2A, it can measure expending energy per hour of general electrical equipment.
5. Measurement and display five parameter of power:active power, apparent power, power factor, reactive power, active energy.
6. There are double scales analogue bar graph to display fluctuation of voltage and current.
7. the instrument is portable and clamp meter. It is very light and convenient to carrying .

## METER LAYOUT

- Clamp jaws  $\Phi 50\text{MM}$
- Hold button  
Holds the display reading and "HOLD" annunciator will appear on the LCD display until pushed this button again, the meter return to normal measurement mode.
- Function switch  
Used to select measurement mode and to turn on/off the instrument.
- LIGHT  
Back light button
- LCD Display  
4 digits display □ 7 segment LCD
- "COM" jack  
The negative ( ground ) input terminal for all measurement modes. Connection is made to it using the black test lead.
- "VHz" jack  
The positive input terminal for volt and frequency measurement . Connection is made to it using the red test lead.

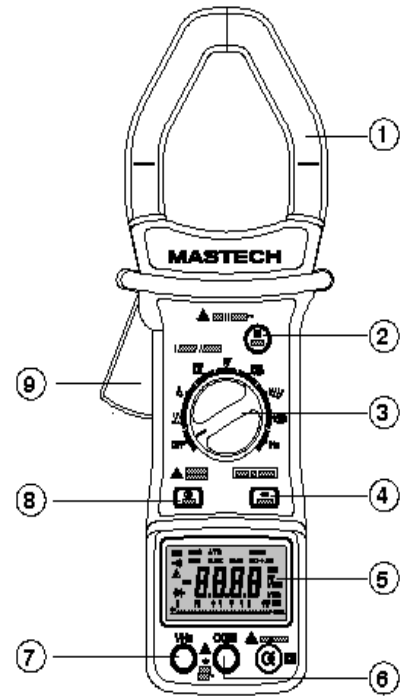

( Figure 1 )

□ MAX

As measuring maximum value , it can be used for Ac voltage , Ac current□active power□apparent power. To press this MAX button,“MAX”annunciator will appear on the LCD.MAX function work, the display keeps the maximum value. Set out MAX Function, just push this MAX button once again.

□ Trigger

Press the lever to open the transformer. When the lever is released, the jaws will close again.

OPERATING INSTRUCTION □

✦ AC VOLTAGE MEASUREMENT □

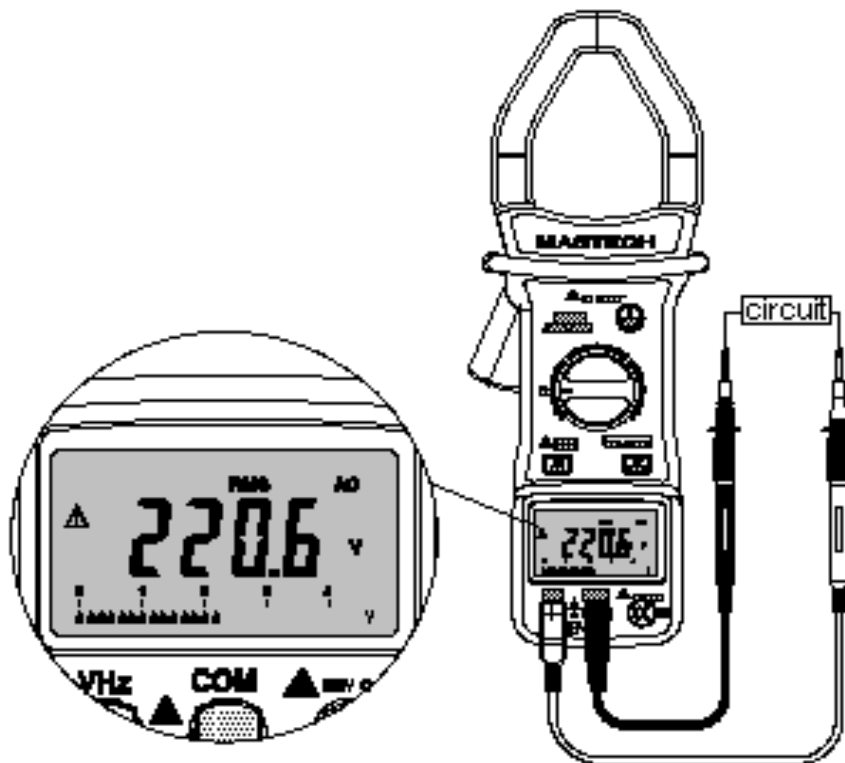

( Figure 2 □ voltage measurement )

1. Connect the red test lead to the "V / HZ" input jack, the black test lead to "COM" input jack respectively.
2. Rotate function switch to desired "V" position, connect test leads to the power supply or the loading to be measured.
3. Read the voltage value on the LCD display.
4. Press the MAX button the display shows "MAX" annunciator, the reading on the display now is maximum (RMS) value. Push this button again the "MAX" annunciator disappears, the reading on the display is current RMS value.
5. For input voltage exceeds 600V the display will shown "OL" annunciator
6. For input voltage exceeds 30V, the display will show "⚠" annunciator to prompt noticing safety.
7. There are two modes to show bar graph on the display you can observe fluctuation of voltage. (Figure 2 and Figure 3)

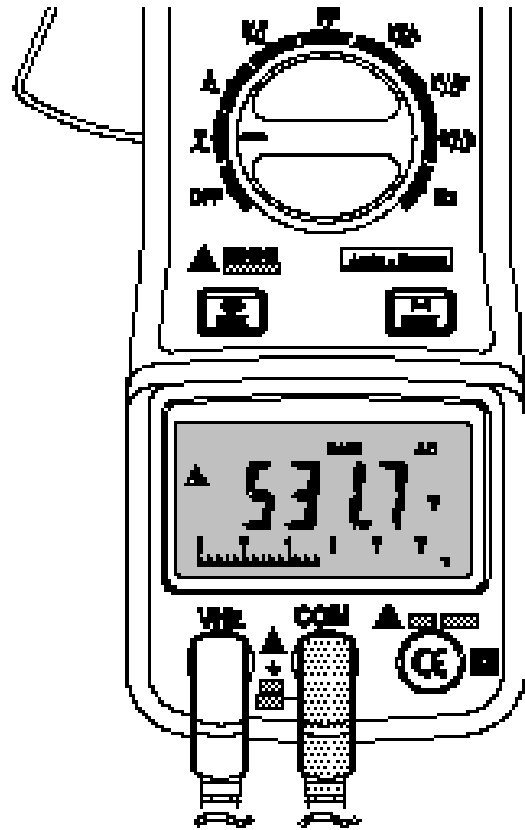

( Figure 3 )

## ✦ AC CURRENT MEASUREMENT

1. Rotate function switch to desired "A" position.
2. Press the trigger to hook the clamp jaw around one conductor to be measured. The display reading is current value (RMS) of the conductor.

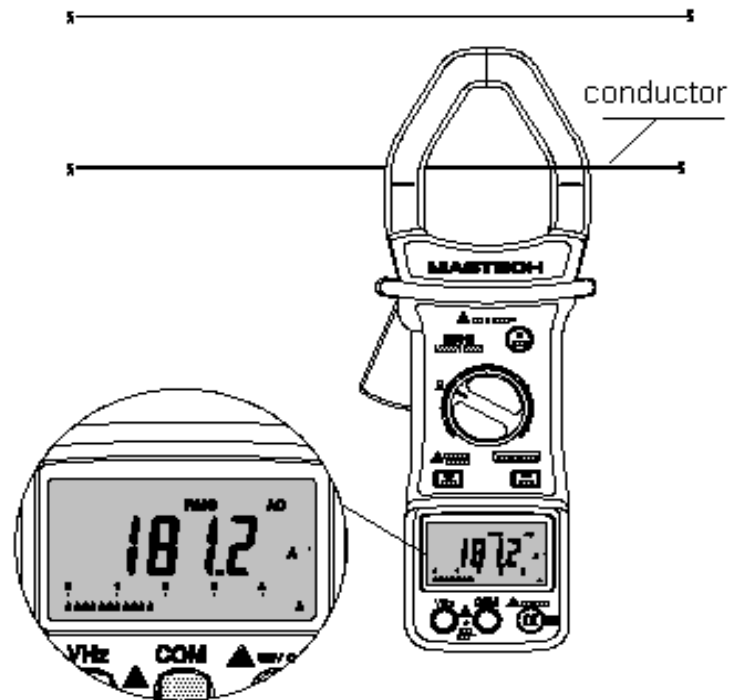

( Figure 4 : current measurement )

3. For current value of conductor to be measured above 1000A (RMS), the display will show the "OL" annunciator.
4. To measure the maximum value of current, press the MAX button.
5. There are two modes to show bar graph to observe the fluctuation range of current. (Figure 4 and Figure 5)



( Figure 5 )



( Figure 6 )

✦ ACTIVE POWER MEASUREMENT

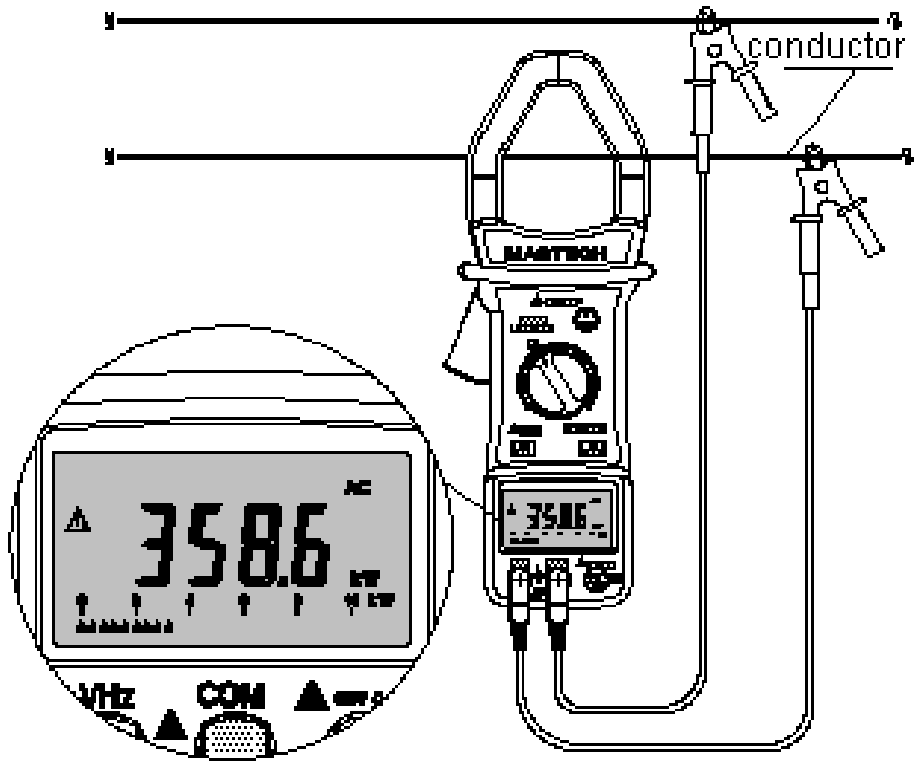

( Figure 7 : power measurement)

1. Rotate function switch to desired "KW" position.
2. Connect the red / black test leads to the "VHz" and "COM" input jacks respectively and apply the test leads tips to the power source or the loading. Hook the clamp jaws around one of the conductor of the power source and the loading.( Figure 7 )
3. The display will show the reading of active power of the tested loading. The maximum measurement range of active power is 600KW. When it exceeds the maximum value , the "OL" annunciator will be shown. If the voltage to be measured exceeds 600V or the current to be measured exceeds 1000A,the "OL" annunciator will be shown on the display, the bar graph is full, "V" or "A" annunciator is shown on the right of the bar graph. The minimum input voltage is 20V and the minimum input current is 0.2A ; when it less than this input voltage and input current, " 0.00KW " will be shown. ( Figure 8 and Figure 9 )
4. Press the MAX button to show the maximum value of active power during measurement.
5. The current input or the voltage input can connect in any direction, It is the same measurement value. In the different measuring condition, you can keep the display face over in order to observe the reading.

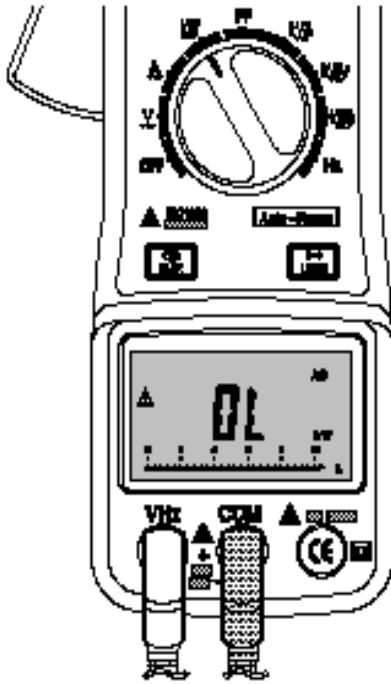

( Figure 8:The current to be measured exceeds 1000A)

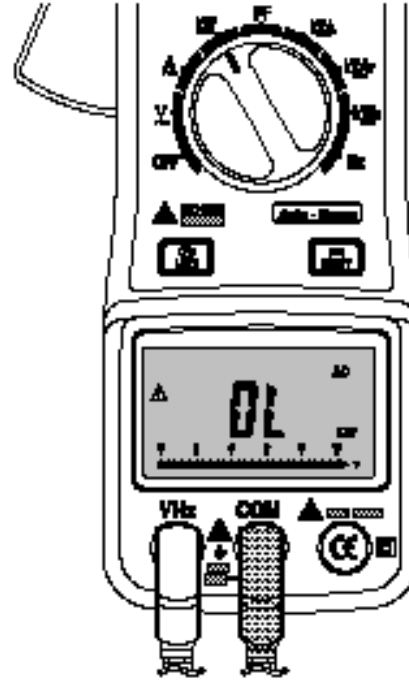

(Figure 9:The voltage to be measured exceeds 600V)

#### ✦ POWER FACTOR MEASUREMENT

i)

1. Rotate function switch to desired "PF" position.
2. Connect the red/black test leads to the "V" and "COM" input jacks respectively , input the voltage to be measured

into the VHz and COM, hook the clamp jaws around one of the current conductors to be tested. ( as Figure 7 )

3. The display will show the power factor value and the "PF" annunciator. When the display appears "—" annunciator, the loading is capacitive.

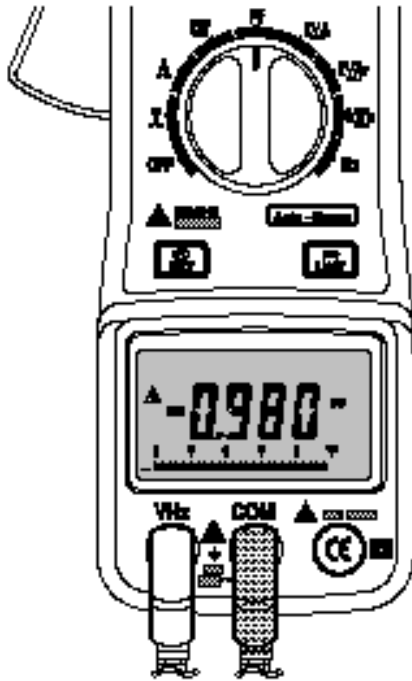

( Figure 10 : power factor of capacitive loading )

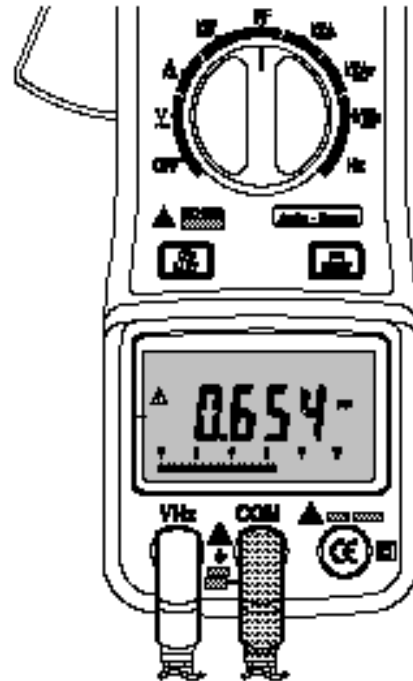

( Figure 11: power factor of inductive loading )

4. When PF measurement mode is selected, the MAX button is invalid.
5. For input voltage less than 20V and input current less than 5A , the display will show " 0.00 " .
6. The bar graph " 0-2-4-6-8-10 " is shown.

✦ **APPARENT POWER MEASUREMENT**

- 1□ Rotate function switch to desired "KVA" position.
- 2□ Connect the red / black test leads to the "VHz" and "COM" input jacks respectively, hook the clamp jaws around the current conductor to be tested. ( as Figure 7 )
- 3□ The display will show "KVA" and the reading of apparent power.  
The bar graph "0-2-4-6-8-10" is shown.
4. Press MAX button, reading the maximum value in measurement mode.
5. If input voltage less than 20V□input current less than 5A, the display will show "0.00KVA".

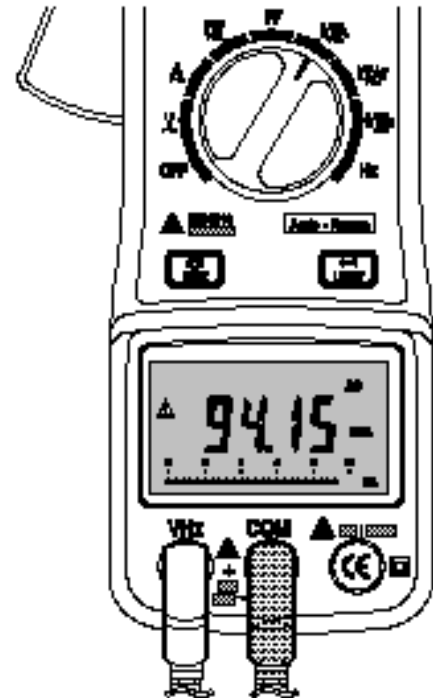

( Figure 12 )

#### ✦ REACTIVE POWER MEASUREMENT

1. Rotate function switch to desired "KVAr" position.
2. Input voltage and current to be measured at the same time.  
(The same KW measurement input mode, Figure 7 )
3. The display shows "KVAr" annunciator and the reading of the reactive power of the loading, the bar graph "0-2-4-6-8-10" is be shown. ( Figure 13 )
4.  $KVAr^2 = KVA^2 - KW^2$  is a formula calculate KVAr value. The value is calculated and shown according to be measured voltage value  $\times$  current value and active power value in software. It is not direct measuring parameter.
5. When reactive power measurement mode is selected, the MAX button is invalid.

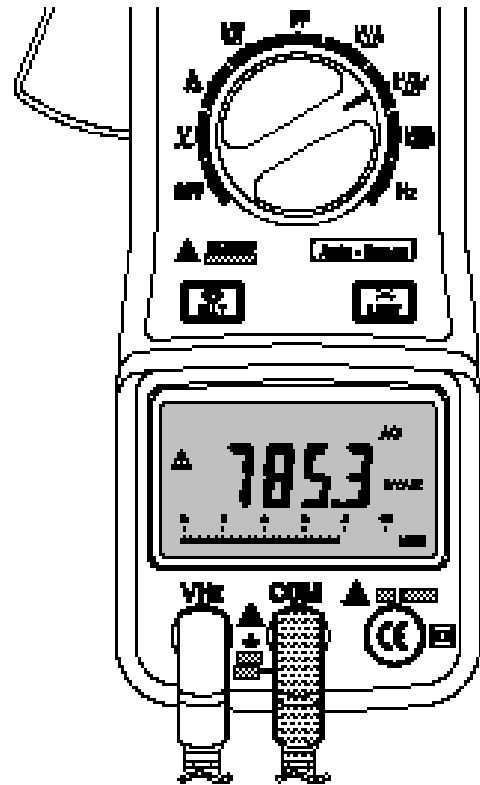

( Figure 13 )

#### ✦ ACTIVE ENERGY MEASUREMENT

1. Rotate function switch to desired "KWh" position.
2. It is the same input method as the active power measurement mode. ( as Figure 7)
3. The display will show the "KWh" and the bar graph "0-2-4-6-8-10", At first the active energy value is "0.000", then the time is longer, the value is larger. If you need read the active energy value at sometime, press the HOLD button, so measuring value is locked. After reading, press the HOLD button again to continue measuring, the reading of active energy is shown successive. Active energy measurement does not stop until the function switch is set in other measurement mode.
4. When active energy measurement mode is selected, the MAX button is invalid.
5. The maximum value of active energy is "9999KW".If the value to be measured exceeds the maximum value, then the display will show the "OL" annunciator.

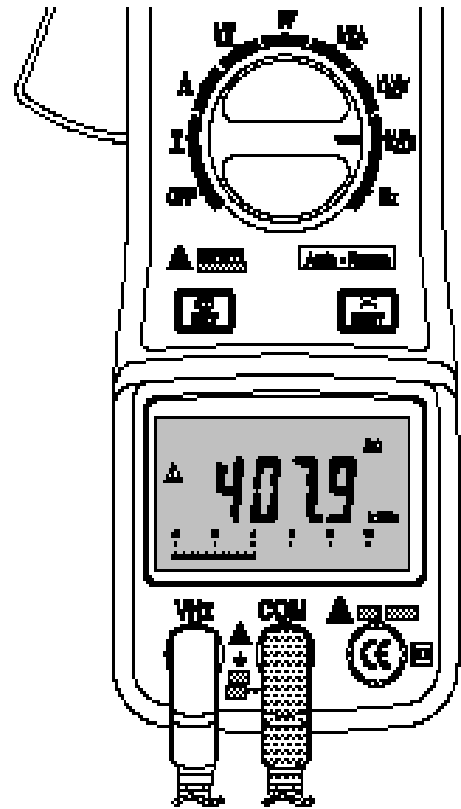

( Figure 14 )

✦ FREQUENCY MEASUREMENT

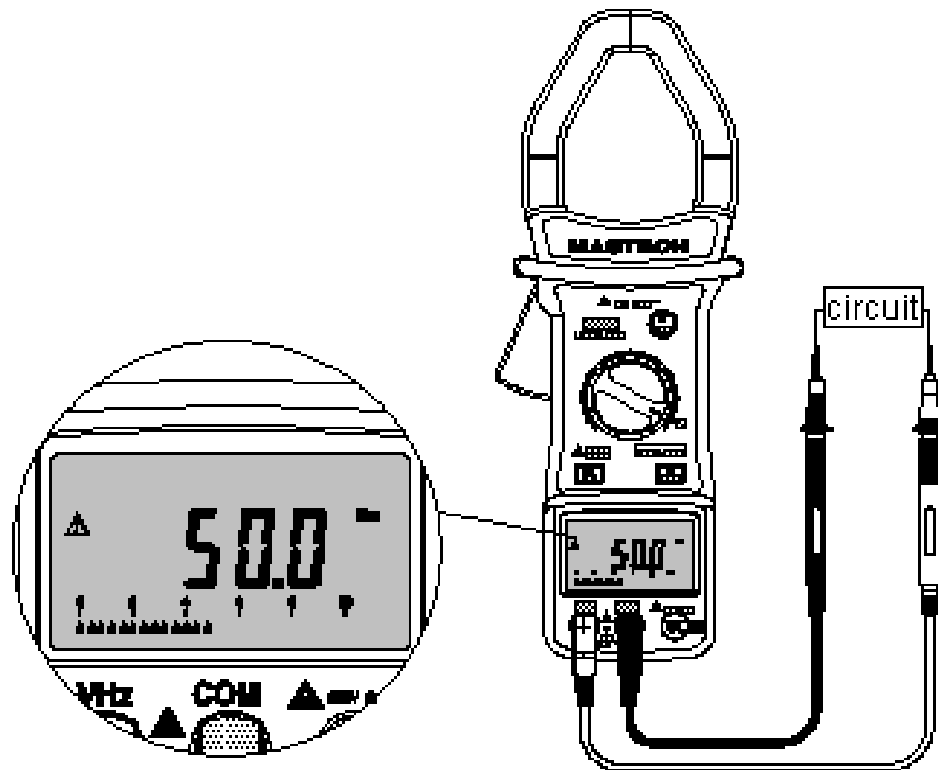

( Figure 15: frequency measurement )

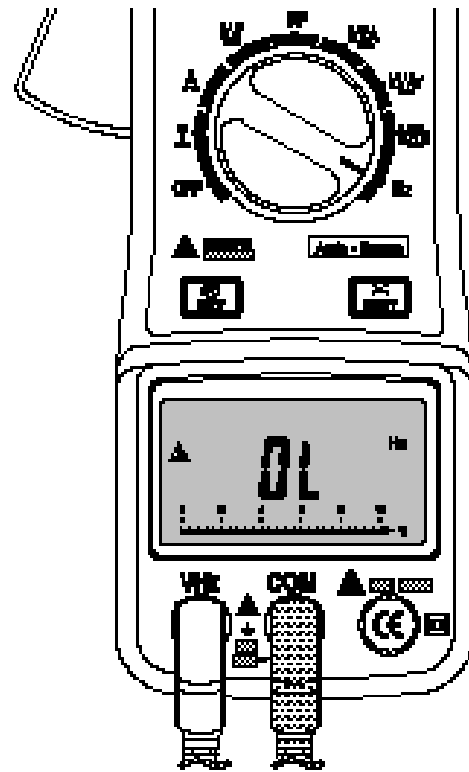

1. Rotate the function switch at desired " Hz" position.
2. Connect the red test lead to "VHz" jack and the black test lead to "COM" jack. ( Figure 15 )
3. The display shows "Hz" annunciator and the frequency value. The bar graph "0-2-4-6-8-10" is shown.
4. If measuring voltage exceeds 600V or measuring current exceeds 1000A, the "OL" annunciator appears on the display, the bar graph is full, the "V" or "A" annunciator is shown on the right of the bar graph. ( Figure 16 )



( Figure 16 )

✦ **TURE RMS MEASUREMENT AND AVERAGE SENSING MEASUREMENT**

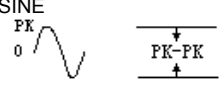
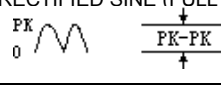
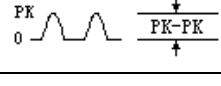
(Figure 17)

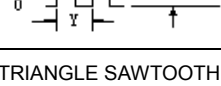
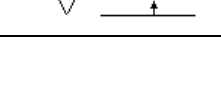
INPUT WAVEFORM	PK-PK	0-PK	RMS	AVG
SINE 	2.828	1.414	1.000	0.900
RECTIFIED SINE (FULL WAVE) 	1.414	1.414	1.000	0.900
RECTIFIED SINE □ HALF WAVE □ 	2.828	2.828	1.414	0.900
SQUARE 	1.800	0.900	0.900	0.900
RECTIFIED SQUARE 	1.800	1.800	1.272	0.900
RECTANGULAR PULSE 	0.9/D	0.9/D	0.9D/2	0.9/D
TRIANGLE SAWTOOTH 	3.600	1.800	1.038	0.900

The TRMS sensing mode can accurately measure the RMS value of the nonsinusoidal input signal. The average-sensing mode measures the average value of a sinusoidal signal and displays it as an equivalent RMS value. Measurement errors are introduced when the input waveform is distorted. The amount of error depends upon the amount of distortion. Figure 17 shows the relationship between sine, square, and triangle waveforms, as well as the required conversion factor.

✦ **DIAGRAM OF CURVE OF POWER**  
**PF=KW/KVA**

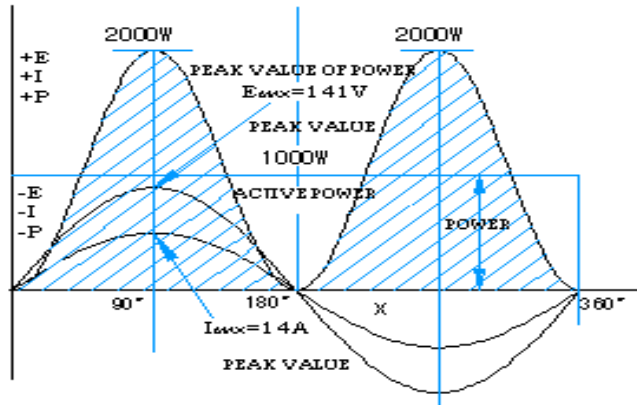

( Figure 18 : PF=1 )

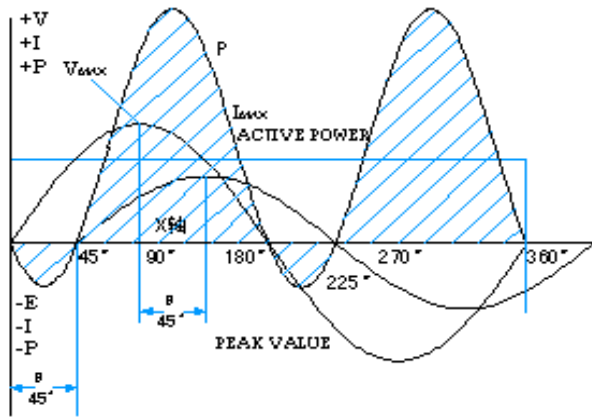

( Figure 19 )

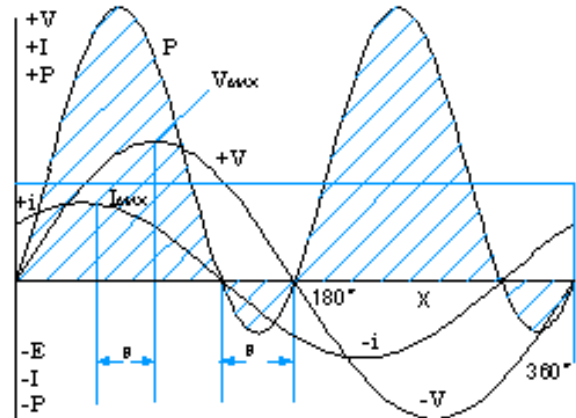

( Figure 20 )

### ✦ BACK LIGHT DISPLAY

When press this button, the back light of LCD display is on . After about 4 seconds, the back light is self-off.

### ✦ INPUT VOLTAGE AND CURRENT

When power measurement mode is selected, if input voltage exceeds 600V  $\square$ RMS $\square$  or current exceeds 1000A  $\square$ RMS $\square$ , the display will show "OL" annunciator. The bar graph is full  $\square$ "V" $\square$  annunciator or "A" annunciator is shown on the right of the bar graph. When input voltage exceeds 30V, " $\triangle$ " annunciator will be displayed to prompt you to notice safety.

✦ **LOW VOLTAGE INDICATION**

The "⏏" annunciator is shown on the top left of the LCD display.

**SPECIFICATIONS**

AC VOLTAGE		RMS	
RANGE	ACCURACY	RESOLUTION	INPUT IMPEDANCE
100V	±(1.2%+5)	0.1V	10 MΩ (10Pf SHUNT)
300V		0.1V	
600V		0.1V	

AC CURRENT		RMS	
RANGE	ACCURACY	RESOLUTION	
40A	±(2%+5)	0.1A	
100A	±(2%+5)	0.1A	
400A	±(2%+5)	0.1A	
1000A	±(2%+5)	0.1A	

**ACTIVE POWER**                      **W=( V×A× COSΦ)**

RANGE	ACCURACY	RESOLUTION
4KVA	±(3%+5)	0.01KW
10KVA	±(3%+5)	0.01KW
40KVA	±(3%+5)	0.01KW
100KVA	±(3%+5)	0.01KW
600KVA	±(3%+5)	0.1KW

Minimum measurement current : 0.2A      Minimum measurement voltage : 20V

**APPARENT POWER**                      **VA=V×A**

RANGE	ACCURACY	RESOLUTION
4KVA	±(3%+5)	0.01KVA
10KVA	±(3%+5)	0.01KVA
40KVA	±(3%+5)	0.01KVA
100KVA	±(3%+5)	0.01KVA
600KVA	±(3%+5)	0.1KVA

Minimum measurement current : 5A      Minimum measurement voltage : 20V

**POWER FACTOR**

$$\square PF=W / VA \square$$

RANGE	ACCURACY	RESOLUTION
0.3□1 Capacitive	±(0.02+2)	0.001
0.3□1 Inductive	±(0.02+2)	0.001

Minimum measurement current : 5A

Minimum measurement voltage : 20V.

**REACTIVE POWER**

$$(Var)^2=(VA)^2+W^2$$

RANGE	ACCURACY	RESOLUTION
4KVA	±(4%+5)	0.01KVAr
10KVA	±(4%+5)	0.01KVAr
40KVA	±(4%+5)	0.01KVAr
100KVA	±(4%+5)	0.01KVAr
600KVA	±(4%+5)	0.1KVAr

Minimum input current : 5A

Minimum input voltage : 20V

Recording Voltage value□current value□active power value to calculate reactive power value,

The calculating accuracy is 0.01% of the range.

**ACTIVE ENERGY**      □KWh□

RANGE	ACCURACY	RESOLUTION
1□9999KWh	±(3%+2)	0.001KWh

Minimum measurement current : 0.2A

Minimum measurement voltage : 10V

**FREQUENCY**      (Hz)

RANGE	ACCURACY	RESOLUTION
20Hz□1KHz	0.5%	0.1Hz

Minimum measurement voltage: 20V.

- \* Accuracy□% of reading + number of digits

The specification given assume an operating temperature: 18°C□28°C, humidity up to: 80% , the frequency of voltage and current is 45Hz□65Hz..

- \* Maximum common made voltage: 600V AC
- \* Display : LCD 9999
- \* Range : autorange
- \* Overrange indication: Figure "OL" on the display
- \* Reading Holding: Figure "HOLD" on the display
- \* Power supply : 9V 6F22

- \* Power consume: 250mW
- \* Storage temperature: -20°C□70°C
- \* Dimension size: 282mm×104mm×47mm
- \* Weight: approximate 500g ( include battery )

## **ACCESSORIES**□

Operation manual	( 1 piece )
9 volt 6F22 battery	( 1 pcs )
Test Leads	( 1 pairs )
Connect clamp	(1 pairs )
Carry Case	( 1 piece )

## PRINCIPIUM CONFIGURATION

